

Theory Exam

Durian Picking

Durian, known as the King of Thai fruits for its unique taste, appearance, and smell, can grow over 30 meters tall. Picking a thorny and heavy durian fruit from such a height requires careful planning.



Figure P-1: the durian fruits on the tree.

In this exam, you will use physics to explore the process of durian picking. To simplify the analysis, the durian fruit will be approximated as a point particle, disregarding its shape and dimensions.

For each question, clearly present all equations used in solving the problem and show your calculations within the designated space in the answer sheet.

Use the gravitational acceleration $g = 9.80 \text{ m/s}^2$ wherever needed.

All numerical answers must contain three significant figures.

P1. [0.5 pt] A durian fruit with a mass of $m_d = 4.00 \text{ kg}$ is dropped from a branch at a height of $h = 12.0 \text{ m}$ above the ground. Calculate the speed of the durian fruit at the instant it reaches the ground, disregarding air resistance.

Solution:

Method 1

Use conservation of mechanical energy, set ground level as a ref. level ($U_g=0$):

$$(0.3 \text{ pt}) \quad m_d g h = \frac{1}{2} m_d v^2 \quad (1)$$

$$v = \sqrt{2gh} \quad (2)$$

$$(0.2 \text{ pt}) \quad v = 15.3 \text{ m/s} \quad (3)$$

Method 2

Use one of the kinematic equation:

$$(0.3 \text{ pt}) \quad v^2 = u^2 + 2gh \quad (1)$$

$$v = \sqrt{2gh} \quad (2)$$

$$(0.2 \text{ pt}) \quad v = 15.3 \text{ m/s} \quad (3)$$

No unit or wrong unit for the answer (-0.1 pt)

Not using three significant figures (-0.1 pt)

Using other valid physics to solve the problem and obtaining the correct answer would result in a full mark.

P2. [1.0 pt] If the impact time is $\Delta t_i = 2.00 \times 10^{-2}$ s, determine the average impulsive force exerted on the durian fruit when it hits the ground, assuming that the durian does not bounce after the collision. (Impact time is defined as the time duration starting from the moment the surface of the durian fruit touches the ground until the durian fruit comes to rest.)

Solution

Impulsive force:

$$(0.3 \text{ pt}) \quad \vec{F}_{\text{imp}} = \frac{\Delta \vec{p}}{\Delta t} \quad (1)$$

Assign positive sign for upward direction:

$$(0.2 \text{ pt}) \quad \Delta p = 0 - (-m_d \cdot v) = m_d \cdot v \quad (2)$$

$$(0.3 \text{ pt}) \quad F_{\text{imp}} = \frac{m_d v}{\Delta t_i} = \frac{4.00 \text{ kg} \times 15.3 \text{ m/s}}{2.00 \times 10^{-2} \text{ s}} = 3.06 \text{ kN} \quad (3)$$

(0.2 pt) Direction: upward

No unit or wrong unit for the answer (-0.1 pt)

Not using three significant figures (-0.1 pt)

If the value of v from P1 is wrong and is used in this problem with correct calculation, The student will get full marks.

If the student write only a line in equation (3) with correct result, full marks will be given.

P3. [1.5 pt] To prevent damage to the durian fruit, a professional durian picker uses a gunny sack to catch the falling durian fruit before it hits the ground. Consider the same durian fruit with mass m_d dropped from the same height h as in question P1. Now, the durian picker uses a gunny sack to catch the durian fruit at a height of $h_p = 1.50$ m above the ground as shown in the Figure P-2. Assume that the picker applies a constant force to the gunny sack, bringing the durian fruit to a halt just before it touches the ground.

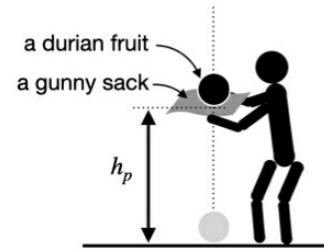

Figure P-2: The picker uses a gunny sack to catch a durian fruit.

- (a) Calculate the acceleration of the durian fruit during the catch.
 (b) Calculate the magnitude of the force the picker uses to catch the durian fruit.

Solution

- (a) Find the speed of the durian fruit just before it hits the sack:

$$v = \sqrt{2g(h - h_p)} \quad (1)$$

(0.2 pt) $v = 14.3$ m/s (2)

Find the acceleration, use one of the kinematic equations with positive sign assigned to upward direction:

$$v^2 = u^2 + 2a\Delta y \quad (3)$$

$$a = -\frac{u^2}{2\Delta y} \quad (4)$$

(0.3 pt) $a = -\frac{(-14.3 \text{ m/s})^2}{2 \times (-1.5) \text{ m}} = 68.2 \text{ m/s}^2$ (5)

(0.2 pt) direction: upward

Giving negative number for a will also get full marks.

No unit or wrong unit for the answer (-0.1 pt)

Not using three significant figures (-0.1 pt)

Different numerical answers due to rounding will also be accepted.

- (b) From Newton's second law:

(0.2 pt) $\Sigma F_y = ma_y$ (6)

(0.2 pt) $-mg + F_{\text{catch}} = ma_y$ (7)

(0.2 pt) $F_{\text{catch}} = m(a_y + g)$ (8)

(0.2 pt) $F_{\text{catch}} = 4.00 \text{ kg} \cdot (68.2 + 9.80) \text{ m/s}^2 = 312 \text{ N}$ (9)**

Starting with (8) without (6) and (7) will also get 0.6pt.

No unit or wrong unit for the answer (-0.1 pt)

Not using three significant figures (-0.1 pt)

Different numerical answers due to rounding will also be accepted.

P4. [1.0 pt] The method described in question B3 remains risky due to the falling durian fruit's proximity to the durian picker's head and hands. Additionally, the picker must repeatedly lower their body and bend their knees, expending excessive effort and energy. A safer and more efficient approach involves the picker holding one edge of the gunny sack and swinging it to catch the falling durian fruit. As the durian fruit initially touches the gunny sack, the picker redirects it toward himself, causing it to descend between his legs and come to a halt before striking the ground as shown in Fig. P-3 (a).

To simplify the problem, let's disregard how the velocity is redirected and how the force is applied through the gunny sack to the durian fruit. Then let's assume that the durian fruit is a point particle and consider the problem as follows. The catching process starts from point A and ends at point B in a straight line trajectory as shown in Fig. P-3 (b). At the point A, the durian fruit's speed v matches that of the falling durian fruit at $h_p = 1.50$ m above the ground as in question P3 but with a different direction. The durian picker applies a constant force to the durian fruit throughout its trajectory so that the durian fruit comes to a complete stop at point B.

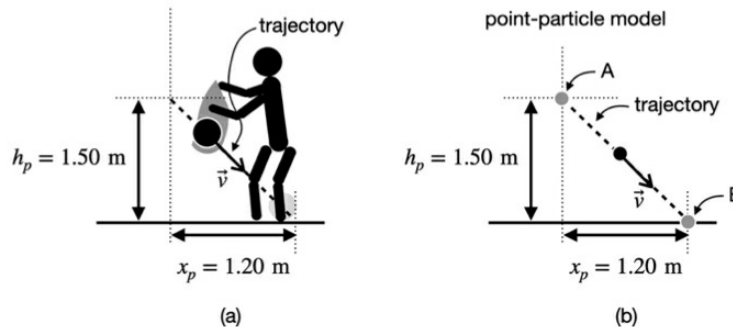

Fig. P-3(a) The durian fruit's trajectory from problem P4. (b) The diagram for simplified problem.

- Calculate the magnitude of the acceleration of the durian fruit during this catch.
- Calculate the magnitude of the net force (\vec{F}_{net}) exerts on the durian fruit during this catch.

Solution

(a) The distance along the trajectory is

$$s = \sqrt{h_p^2 + x_p^2} = \sqrt{1.50^2 + 1.20^2} = 1.92 \text{ m} \quad (1)$$

From equation (4) in P3, positive direction is pointing up along the inclined path:

$$a = -\frac{u^2}{2s} \quad (2)$$

$$(0.5 \text{ pt}) \quad a = -\frac{(-14.3)^2}{2 \times (-1.92)} \text{ m/s}^2 = 53.3 \text{ m/s}^2 \quad (3)^{**}$$

No unit or wrong unit for the answer (-0.1 pt)

Not using three significant figures (-0.1 pt)

Different numerical answers due to rounding will also be accepted.

(b) From Newton's second law of motion:

$$\Sigma \vec{F} = \vec{F}_{\text{net}} = m\vec{a} \quad (4)$$

$$\vec{F}_{\text{net}} = m\vec{a} \quad (5)$$

$$(0.5 \text{ pt}) \quad F_{\text{net}} = 4.00 \text{ kg} \times 53.3 \text{ m/s}^2 = 213.2 \text{ N} \approx 213 \text{ N} \quad (6)^{**}$$

No unit or wrong unit for the answer (-0.1 pt)

Not using three significant figures (-0.1 pt)

Different numerical answers due to rounding will also be accepted.

P5. [2.0 pt] (a) Draw a diagram of the durian fruit during the trajectory in the question P4 into a given coordinates in the answer sheet, as also shown in Fig. P-4. The diagram must show the gravitational force on the durian fruit $m_d \vec{g}$, the net force \vec{F}_{net} , and the force exerted by the durian picker through the gunny sack \vec{F}_{picker} .

(b) Calculate the magnitude of the force \vec{F}_{picker} and the angle ϕ (in degrees) between \vec{F}_{picker} and y-axis.

Solution

(a) (0.8 pt)

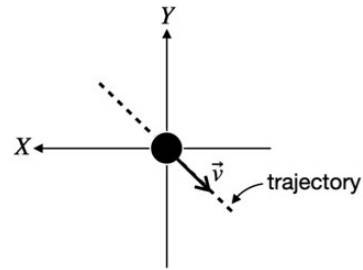
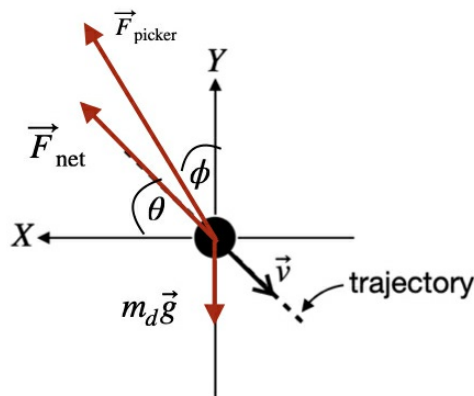

Figure P-4: The coordinates for problem P5.



(0.2 pt) correct direction of $m_d \vec{g}$

(0.2 pt) correct direction of \vec{F}_{net}

(0.4 pt) correct direction of \vec{F}_{picker} (being between \vec{F}_{net} and Y-axis)

If \vec{F}_{picker} is written somewhere else, get only 0.1 pt.

(b) (1.2 pt) Consider x component of forces:

$$F_{\text{picker},x} = F_{\text{net},x} = F_{\text{net}} \cos \theta \quad (1)$$

From dimensions given in P4.,

$$(0.1 \text{ pt}) \quad \theta = \tan^{-1} \left(\frac{1.50}{1.20} \right) = 51.3^\circ \quad (2)$$

$$(0.3 \text{ pt}) \quad F_{\text{picker},x} = F_{\text{net}} \cos \theta = 213 \times \cos 51.3^\circ = 133.2 \text{ N} \quad (3)$$

Consider y component of forces:

$$F_{\text{picker},y} = F_{\text{net},y} + mg = F_{\text{net}} \sin \theta + mg \quad (4)$$

$$(0.3 \text{ pt}) \quad F_{\text{picker},y} = 213 \times \sin 51.3^\circ + (4.00 \times 9.80) = 205.4 \text{ N} \quad (5)$$

Therefore,

$$(0.2 \text{ pt}) \quad F_{\text{picker}} = \sqrt{F_{\text{picker},x}^2 + F_{\text{picker},y}^2} = 244.8 \text{ N} \approx 245 \text{ N} \quad (6)^{**}$$

$$(0.3 \text{ pt}) \quad \phi = 90^\circ - \tan^{-1} \left(\frac{F_{\text{picker},y}}{F_{\text{picker},x}} \right) = 33.0^\circ \quad (7)^{**}$$

Using cosine rule and get correct F_{picker} will get full marks (0.9 pt).

Not using three significant figures (-0.1 pt).

Different numerical answers due to rounding will also be accepted.

P6. [2.0 pt] In a single branch, it's common to find multiple durian fruits. The farmer must employ a plastic rope to support the thin branch and prevent it from breaking under the weight of the durian fruits. To simplify the problem, let's assume the branch with a length of $L = 5.00$ m has a uniform mass of $m_b = 6.00$ kg, and all of the durians depicted in Figure P-5 have an identical mass of $m_d = 4.00$ kg each. A joint between the branch and the stem provides $M_j = 150$ N · m clockwise moment as shown in Figure P-5. The plastic rope is tied at the locations also shown in the Figure P-5.

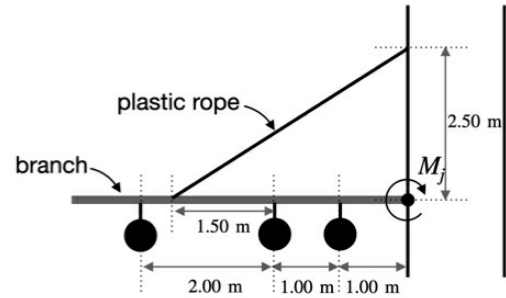
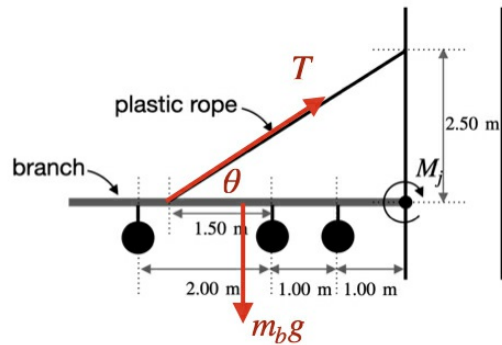

Figure P-5: The configuration of the durian fruits on a single branch for

Calculate the tension in the plastic rope.



Solution

Consider moments about the joint and assign a positive sign to the clockwise direction,

$$\Sigma M_{\text{joint}} = 0 = (-m_d g \times 4.00) + (-m_d g \times 2.00) + (-m_d g \times 1.00) + (-m_b g \times 2.50) + (T \sin \theta \times 3.50) + M_j$$

$$\sin \theta = \sin \left(\tan^{-1} \left(\frac{2.50}{3.50} \right) \right) = 0.581$$

$$0 = (-m_d g \times 7.00) + (-m_b g \times 2.50) + (T \times 0.581 \times 3.50) + 150 \text{ N} \cdot \text{m}$$

$$T = \frac{(m_d g \times 7.00) + (m_b g \times 2.50) - 150}{0.581 \times 3.50} = \frac{271.4}{2.0335} = 133.5 \text{ N}$$

(0.3 pt) for using $\Sigma M_{\text{joint}} = 0$

(0.6 pt) for correct moment of three durians

(0.3 pt) for correct moment of the rope

(0.2 pt) for correct moment of the branch

(0.2 pt) for correct inclusion of M_j

(0.4 pt) for correct T

Not using three significant figures (-0.1 pt).

Different numerical answers due to rounding will also be accepted.

In southern Thailand, many orchards cultivate durian trees and other tropical fruits on sloping terrains. As fallen durians can roll downhill and pose a potential hazard, it's essential to exercise caution when walking in these orchards.

P7. [1.0 pt] Assume that 0.001% of the kinetic energy of the durian fruit in problem P1 just before the impact, as described in problem P2, is converted into sound energy. Given that the sound energy that hits the ground get absorbed by the ground, calculate the sound intensity level (in decibels, dB) of the impact sound at a distance of $r = 10.0$ m from the point where the durian fruit hits the ground.

Additional Information: The sound intensity level β is a logarithmic measure of its intensity $I = P/A$, where P is the power and A is the area. The sound intensity level is defined by

$$\beta = (10 \text{ dB})\log\left(\frac{I}{I_0}\right), \text{ where } I_0 = 1.00 \times 10^{-12} \text{ W/m}^2.$$

Solution **Ans 82.7 dB**

Kinetic energy of the durian fruit right before it touches the ground can be calculated from conservation of mechanical energy,

kinetic energy = gravitational energy

$$(0.2 \text{ pt}) \quad mgh = 4.00 \text{ kg} \times 9.80 \text{ m/s}^2 \times 12.0 \text{ m} = 470.4 \text{ J}$$

0.001% of this energy is converted into sound energy,

$$(0.1 \text{ pt}) \quad \text{sound energy} = 470.4 \times 10^{-5} \text{ J} = 4.70 \times 10^{-3} \text{ J}$$

The sound energy radiated uniformly during the impact,

$$(0.2 \text{ pt}) \text{ sound power} = \text{sound energy}/\text{impact time} = \frac{4.70 \times 10^{-3} \text{ J}}{2.00 \times 10^{-2} \text{ s}} = 0.235 \text{ W}$$

sound intensity at $r = 10.0$ m,

$$(0.2 \text{ pt}) \quad I = \frac{P}{A}, \quad I_{10\text{m}} = \frac{0.235 \text{ W}}{4\pi \times 10.0^2 \text{ m}^2} = 1.87 \times 10^{-4} \text{ W/m}^2$$

Therefore, the sound intensity level at this location is,

$$(0.3 \text{ pt}) \quad \beta = (10 \text{ dB})\log\left(\frac{I}{I_0}\right) = (10 \text{ dB})\log\left(\frac{1.87 \times 10^{-4}}{10^{-12}}\right) = 82.7 \text{ dB}$$

Not using three significant figures (-0.1 pt).

Different numerical answers due to rounding will also be accepted.

P8. [1.0 pt] Determine the distance from the impact point, as described in problem P7, at which the sound intensity level of the impact reaches 60 dB —a level that is easily noticeable in an orchard environment.

Solution (1.0 pt) $r = 137$ meters

From the sound intensity level formula,

$$\beta = (10 \text{ dB})\log\left(\frac{I}{I_0}\right),$$

$$60 \text{ dB} = (10 \text{ dB})\log\left(\frac{I_{60\text{dB}}}{I_0}\right)$$

(0.4 pt) $I_{60\text{dB}} = 10^{-6} \text{ W/m}^2.$

This sound intensity is produced by a source power P at a distance r ,

(0.2 pt) $I_{60\text{dB}} = \frac{P}{4\pi r^2}$

(0.4 pts) $r = \sqrt{\frac{P}{4\pi I_{60\text{dB}}}} = \sqrt{\frac{0.235}{4\pi \times 10^{-6}}} = 136.8 \text{ m} \approx 137 \text{ m}$

Not using three significant figures (-0.1 pt).

Different numerical answers due to rounding will also be accepted.

C-1.1) (2.5pt) The mangostin molecule contains atoms of three elements. Mangostin vapour is 14.65 times denser than gaseous nitrogen. Pure mangostin with a mass of 1.000 g was burned in excess oxygen gas to produce only water and carbon dioxide. The water is collected in an absorber and the mass change of this absorber is equal to 0.570 g. The carbon dioxide is collected in a separate absorber filled with 100.00 cm³ of 2.00 M sodium hydroxide solution (NaOH). A volume of 25.00 cm³ of this solution was titrated with 2.00 M hydrochloric acid solution (HCl) using 5 drops of methyl orange as indicator (pH range 3.2-4.4). A titration volume of 25.00 cm³ of HCl solution was consumed. The same volume of the solution was titrated with 2.00 M HCl solution using phenolphthalein as indicator (pH range 8.3-10.0) required 17.70 cm³ of HCl solution. Write the formula of mangostin. (H_2CO_3 ; $K_{a1} = 4.2 \times 10^{-7}$, $K_{a2} = 4.8 \times 10^{-11}$)

Solution:

The empirical formula of the mangostin can be calculated from the composition of combustion products of this compound:

$$(1) \text{ mole of H} = (0.570 \text{ g H}_2\text{O}) \left(\frac{1 \text{ mol H}_2\text{O}}{18.02 \text{ g H}_2\text{O}} \right) \left(\frac{2 \text{ mol H}}{1 \text{ mol H}_2\text{O}} \right) = \mathbf{0.0633 \text{ mol}} \quad (0.3)$$

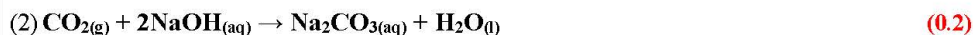

Titration reaction	Volume of HCl required for reaction (cm ³)	
	Phenolphthalein	Methyl orange
HCl(aq) + NaOH(aq) _{leftover} → NaCl(aq) + H ₂ O(l)	x	x
HCl(aq) + Na ₂ CO ₃ (aq) → NaHCO ₃ (aq) + NaCl(aq)	y	y
HCl(aq) + NaHCO ₃ (aq) → NaCl(aq) + CO ₂ (g) + H ₂ O(l)	-	y
The volume of HCl required for complete reaction	x+y = 17.70	x+2y = 25.00

$$(3) \text{ mole of CO}_2 = \text{mole of Na}_2\text{CO}_3 = \left(\frac{2.00 \text{ mol HCl}}{1 \text{ L HCl}} \right) \left(\frac{1 \text{ L HCl}}{1000 \text{ mL HCl}} \right) (25.00 - 17.70 \text{ mL HCl}) = \mathbf{0.0146 \text{ mol}} \quad (0.3)$$

$$(4) \text{ mole of C} = (0.0146 \text{ mol CO}_2) \left(\frac{100.00 \text{ mL soln}}{25.00 \text{ mL soln}} \right) \left(\frac{1 \text{ mol C}}{1 \text{ mol CO}_2} \right) = \mathbf{0.0584 \text{ mol}} \quad (0.3)$$

$$(5) \text{ mass of O} = (1.000 \text{ g mangostin}) - (0.0633 \text{ mol H})(1.01 \text{ g/mol}) - (0.0584 \text{ mol C})(12.01 \text{ g/mol}) = 0.235 \text{ g}$$

$$\text{mole of O} = (0.235 \text{ g O}) \left(\frac{1 \text{ mol O}}{16 \text{ g O}} \right) = 0.0147 \quad (0.3)$$

$$(6) \text{ mole ratio C : H : O of mangostin} = 0.0584 : 0.0633 : 0.0147 = \mathbf{3.97 : 4.31 : 1.00} \quad (0.3)$$

$$= 3.97 : (4.00 + 1/3) : 1.00$$

Multiply the whole number by 3 = 12 : (12 + 1) : 3

$$(7) \text{ mole ratio; multiply by 3} = 12 : 13 : 3 \quad (0.2)$$

empirical formula of mangostin is **C₁₂H₁₃O₃**

molecular formula of mangostin is (C₁₂H₁₃O₃)_n

mass of empirical formula = n × (205.25)

(8) molar mass of mangostin is calculated in the following way:

$$d = M(P/RT)$$

$$M(\text{mangostin}) = M(\text{N}_2) \times \frac{d(\text{mangostin})}{d(\text{N}_2)} = \left(\frac{14.01 \times 2 \text{ g N}_2}{1 \text{ mol N}_2} \right) \times 14.65 = \mathbf{410.5 \text{ g mol}^{-1}} \quad (0.2)$$

$$(9) n = \left(\frac{410.5 \text{ g mangostin}}{205.25 \text{ g mangostin}} \right) = 2 \quad (0.2)$$

(10) Molecular formula of the mangostin is $C_{24}H_{26}O_6$ (0.2)

Remark:

If the answer is given as $C_{24}H_{24}O_6$, 0.6 points will be subtracted. (uses C_4H_4O empirical formula, $n = 6$)

C-2.1) (2.0pt) Ethanethiol can react with hydrogen peroxide to produce diethyl disulfide and water. How many liters of diethyl disulfide will be produced via ethionine pathway from the reaction of 100.0 g of Monthong pulp with hydrogen peroxide at 160.00°C and 0.5000 atm ($1 \text{ atm} = 1.013 \times 10^5 \text{ Pa}$)? Also provide the balanced chemical equation and report your answer in correct significant figures. Assume that diethyl disulfide behaves as an ideal gas under this condition.

Solution: The balanced reaction equation: $2C_2H_6S + H_2O_2 \rightarrow C_4H_{10}S_2 + 2H_2O$ (+0.3)

According to the graph, [ethionine] = 3930 $\mu\text{g}/\text{kg}$ or 393.0 μg per 100 g of Monthong pulp. (+0.3)

Moles of diethyl disulfide = $\frac{1}{2}$ (moles of ethionine or ethanethiol) (+0.3)

$$= \frac{1}{2} \left(\frac{393.0 \times 10^{-6} \text{ g}}{163.27 \text{ g/mol}} \right)_{\text{ethionine}}$$

$$= 1.204 \times 10^{-6} \text{ mol} \quad (0.3)$$

Assuming ideal gas, $PV = nRT$ or $V = nRT/P$. (+0.3)

Therefore, the volume of diethyl disulfide

$$= (1.204 \times 10^{-6} \text{ mol})(0.08206 \text{ L}\cdot\text{atm}/\text{mol}\cdot\text{K})(433.15 \text{ K})/(0.5000 \text{ atm})$$

$$= 8.559 \times 10^{-5} \text{ L} \quad (0.3)$$

(Correct number of significant figures for both mole and volume of diethyl disulfide +0.2)

Remark

Missing or incorrect state condition of each substance in the chemical equation is not penalized. Regardless of whether the chemical equation is correct or not, full credit for the calculations can be given as long as the calculations are consistent with the chemical equation.

C-2.2) (1.5pt) If $5.00 \times 10^{-4} \text{ L}$ of gaseous diethyl disulfide is detected at 160.00°C and 0.5000 atm from 100.0 g of Krathum pulp, what is the percent conversion of sulfur from the pulp into diethyl disulfide? Report your answer to correct significant figure and show your calculation in detail. Assume that diethyl disulfide is the only

gaseous organosulfur compound detected from Krathum pulp, and that it behaves as an ideal gas under this condition.

Solution: mol of S in 500×10^{-4} L of diethyl disulphide = $2 \left(\frac{0.5000 \text{ atm} \cdot 5.00 \times 10^{-4} \text{ L}}{0.08206 \text{ (L}\cdot\text{atm/mol}\cdot\text{K)} \cdot 433.15 \text{ K}} \right)$

$$= 1.41 \times 10^{-5} \text{ mol of S} \quad (+0.4)$$

100 g of Krathum pulp contains = $\left(\frac{960.0 \times 10^{-6} \text{ g}}{163.27 \text{ g/mol}} \right)_{\text{ethionine}} + \left(\frac{3020.0 \times 10^{-6} \text{ g}}{149.24 \text{ g/mol}} \right)_{\text{methionine}}$

$$= (0.5880 \times 10^{-5}) + (2.0234 \times 10^{-5})$$

$$= 2.611 \times 10^{-5} \text{ mol of S} \quad (+0.6)$$

% conversion of sulfur = $\frac{1.41 \times 10^{-5}}{2.611 \times 10^{-5}} \times 100 = 54.0\% \quad (+0.3)$

(Correct number of significant figures for % conversion +0.2)

Remark

If the theoretical quantity of S is only derived from either ethionine or methionine, a credit of +0.2 is given instead of +0.4. Regardless of whether the theoretical and the observed amounts of S are correct or not, full credit of +0.3 for the % conversion of S can be given as long as the answer is consistent with the given amounts of S.

C-3.1) (1pt) Pyrite is a mineral form of iron disulfide found in soil, and contains the disulfide ion (S_2^{2-}). It reacts with oxygen causing the soil to acidify by the following reaction:

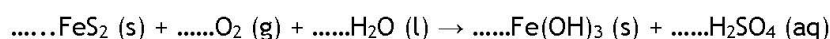

Fill the blank to complete the given equation and show the balancing method used.

Solution:

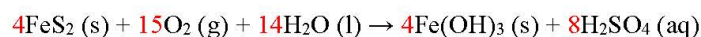

Remark: +1.0 for correct all coefficient number

If student doesn't get correct number, +0.3 for correct half reaction

C-3.2) (1.8pt) 5.0 L of solution has been prepared by treatment of 1 kg of soil which previously contained 2.4 g of pyrite which was completely oxidized to form sulfuric acid. What is the pH of the solution? The pH depends on only sulfuric acid. Assume that sulfuric acid does not react with other components of the soil such as $\text{Fe}(\text{OH})_3$. (H_2SO_4 dissociates completely in the 1st degree, and K_{a2} of $\text{H}_2\text{SO}_4 = 1.0 \times 10^{-2}$)

Solution:

4 mol of FeS_2 gives 8 mol of H_2SO_4

mol of $\text{FeS}_2 = (2.4\text{g}) / (119.99 \text{ g/mol}) = 0.020 \text{ mol}$ (+0.10)

0.020 mol of FeS_2 gives $(8 \times 0.020) / 4 = 0.040 \text{ mol}$ of H_2SO_4 (+0.30)

Concentration of $\text{H}_2\text{SO}_4 = 0.040 \text{ mol} / 5.0 \text{ L} = 0.0080 \text{ mol/L}$ (+0.20)

Concentration of H^+ from 0.0080 mol/L H_2SO_4



$$0.0080 \text{ M} \quad 0.0080 \text{ M} \quad 0.0080 \text{ M}$$



$$(0.0080 - X) \text{ M} \quad (0.0080 + X) \quad X$$

$$K_{a2} = 1.0 \times 10^{-2} = (0.0080 + X)X / (0.0080 - X) \quad \text{(use } K_a \text{ for calculation +0.50)}$$

$$X^2 + 0.018X - (8 \times 10^{-5}) = 0$$

$$X = 0.0037 \text{ M} \quad \text{(get correct number +0.30)}$$

Therefore, $[\text{H}^+] = 0.0080 + 0.0037 = 0.0117 \text{ M}$ (+0.20)

$\text{pH} = -\log(0.0117) = 1.93$ (+0.20)

Remark: There is no double penalty from Question C-3.1

C-3.3) (0.7pt) One of the liming materials is CaCO_3 which is generally used to neutralize soil acidity. In this case, what is the minimum mass in grams of CaCO_3 required to neutralize the solution from C-3.2? (Round your answer to two decimal places)

Solution:

0.04 mol of H_2SO_4 needs 0.04 mol of CaCO_3 (+0.3 for correct stoichiometry)

MW of $\text{CaCO}_3 = 100.09 \text{ g/mol} \rightarrow \text{mass of } \text{CaCO}_3 = (0.04 \text{ mol})(100.09 \text{ g/mol})$

$= 4.00 \text{ g}$ (+0.4 for correct calculation)

Remark: There is no double penalty from Question C-3.2

C-3.4) (0.5pt) The lattice energy of calcium carbonate $\text{CaCO}_3(\text{s})$ is 2804 kJ/mol and the heat of hydration (ΔH_{hydr} of $\text{Ca}^{2+}(\text{g}) = -1579 \text{ kJ/mol}$ and heat of hydration (ΔH_{hydr} of $\text{CO}_3^{2-}(\text{g}) = -1389 \text{ kJ/mol}$. Use these data to calculate the heat of solution (kJ/mol) of calcium carbonate. Show your calculation method.

Use (s), (l), (g), and (aq) for solid, liquid, gas, and aqueous states respectively.

Solution		
Step	Equation	Energy change
(1) \rightarrow (2) Thermochemical equation of lattice energy:	$\text{CaCO}_3(\text{s}) \rightarrow \text{Ca}^{2+}(\text{g}) + \text{CO}_3^{2-}(\text{g})$ (+0.1)	$\Delta H = 2804 \text{ kJ/mol}$
(2) \rightarrow (3) Thermochemical equation of hydration:	$\text{Ca}^{2+}(\text{g}) + \text{CO}_3^{2-}(\text{g}) \rightarrow \text{Ca}^{2+}(\text{aq}) + \text{CO}_3^{2-}(\text{aq})$ (+0.1)	(5) $\Delta H = -2968 \text{ kJ/mol}$
(1) \rightarrow (3) Thermochemical equation of solution:	$\text{CaCO}_3(\text{s}) \rightarrow \text{Ca}^{2+}(\text{aq}) + \text{CO}_3^{2-}(\text{aq})$ (+0.1)	(6) $\Delta H = -164 \text{ kJ/mol}$ (+0.2)

Remarks:

- 0.1 Mark for each correct equation with state indications and its energy change. Must be fully correct for mark.
- Answer for calculating the heat of solution must be negative for mark. Deduct 0.1 marks, if correct unit is not written.



Points: 30

Time: 3 Hours

Part III: Biology [\(Answers and Explanations\)](#)

B1. (1.8pt)

I: Experiment	II: Food (grain)	III: Chickens used in experiment	Expected outcome (A-F), depending on cause of beriberi	
			IV: Bacterial infection	V: Thiamine deficiency
1	Unpolished	One sick and two healthy (0.6pt)	D: The bacteria from the sick chicken is expected to spread to the other two healthy chickens, thus resulting in (D) three sick chickens.	C: The sick chicken is expected to recover, resulting in (C) three healthy chickens.
2	Polished	Four healthy (0.6pt)	E: In this group, there is no sick chicken, thus the four chickens are expected to remain as (E) four healthy chickens.	F: Consuming food with low thiamine should result in thiamine deficiency, thus the answer is (F) four sick chickens.
3	Unpolished	Two healthy (0.6pt)	A: In this group, there is no sick chicken, thus the two chickens are expected to remain as (A) two healthy chickens.	A: Unpolished grain contains thiamine, thus consumption of unpolished grain by healthy chickens should not make them sick, thus the answer is (A) two healthy chickens.



Points: 30

Time: 3 Hours

Marking Scheme

0.3pt for each correct answer.

References

Urry, L. A., Cain, M. L., Wasserman, S. A., Minorsky, P. V., Orr, R. B., & Campbell, N. A. (2021). *Campbell biology* (12th ed.). Pearson. pp. 898-920.

<https://www.nobelprize.org/prizes/medicine/1929/eijkman/lecture/>

B2. (1.9pt)

Question	Answer	Explanation
1. When students eat protein, in which organ (P-T) does the first enzymatic digestion occur? (0.2pt)	R	Enzymatic digestion of proteins first occurs in stomach.
2. What kind of tissue (TT) mainly covers the internal surface of the organ R? (0.3pt)	3. SIMPLE COLUMNAR EPITHELIUM	Main tissues of the internal surface of stomach are simple columnar epithelium.
3. Which image (A-J) shows the morphology of squamous stratified epithelium? (0.2pt)	B	squamous stratified epithelium is multiple layer of squamous cells.
4. In which organ (P-T) is the protein completely digested? (0.2pt)	P	Proteins are completely digested in small intestine.
5. The nutrients are transported to other cells in the body by what tissue (TT)? (0.3pt)	8. BLOOD	The digested molecules are transported to other cells via blood circulation, the special connective tissue type.

<p>6. Which image (A-J) shows the morphology of muscle tissue that controls jaw movements? (0.2pt)</p>	<p>H</p>	<p>H is skeletal muscle.</p>
<p>7. Which muscle tissue (TT) controls the movement within the organ P? (0.3pt)</p>	<p>4. SMOOTH MUSCLE</p>	<p>Smooth muscle tissue contracts without any voluntary control and generally controls movement of organs in a digestive system.</p>
<p>8. Which image (A-J) shows the morphology of the muscle tissue in organ R? (0.2pt)</p>	<p>I</p>	<p>Smooth muscle tissue consists of spindle-shaped cells with a single centrally located nucleus.</p>

Marking Scheme for 1, 3, 4, 6 and 8: 0.2pt for each correct answer

Marking Scheme for 2, 5, and 7: 0.3pt for each correct answer

Reference

Urry, L. A., Cain, M. L., Wasserman, S. A., Minorsky, P. V., Orr, R. B., & Campbell, N. A. (2021). *Campbell biology* (12th ed.). Pearson. pp. 873-897.

B3. (1.4pt)

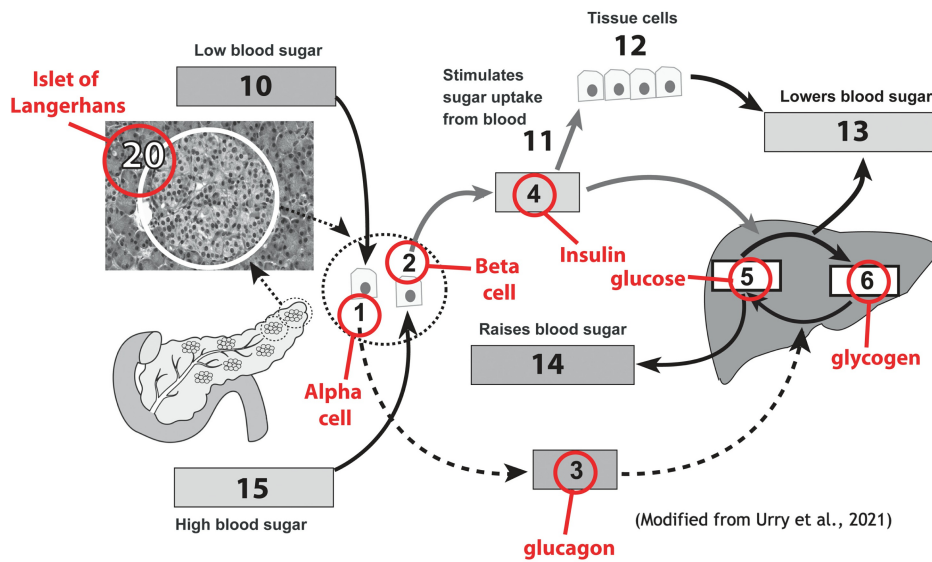

Question		Answer	Explanation
1	Name the structure enclosed by the dotted circle 20	C. Islet of Langerhans	The islets of Langerhans are richly vascularized spherical clusters of endocrine cells located within the pancreas.
2	Name Cell 1 (produces Hormone 3)	I. Alpha cell	Alpha cells of the pancreas secrete the hormone glucagon into the blood.
3	Name Hormone 3	E. Glucagon	Glucagon promotes the breakdown of glycogen in the liver and the release of glucose into the blood.
4	What is denoted by the number 6?	P. Glycogen	When the blood glucose level drops below the normal range, the secretion of glucagon promotes the release of glucose into the blood from energy stores, such as liver glycogen, increasing the blood glucose concentration.
5	Name Cell 2 (produces Hormone 4)	J. Beta cell	Beta cells of the pancreas secrete the hormone insulin into the blood.
6	Name Hormone 4	F. Insulin	Insulin enhances the transport of glucose into body cells and stimulates the liver to store glucose as glycogen.
7	What is denoted by the number 5?	N. Glucose	When the blood glucose level rises above the normal range, insulin secretion triggers glucose uptake from the blood into body cells, decreasing the blood glucose concentration.

Marking Scheme

0.2pt for each correct answer



Points: 30

Time: 3 Hours

Reference

Urry, L. A., Cain, M. L., Wasserman, S. A., Minorsky, P. V., Orr, R. B., & Campbell, N. A. (2021). *Campbell biology* (12th ed.). Pearson. pp. 916-917.

B4. (1.3pt)

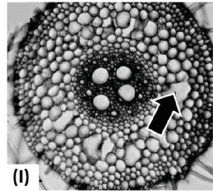
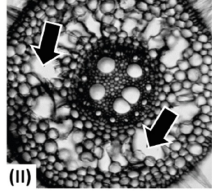
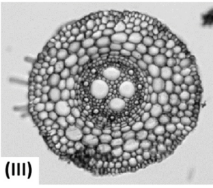
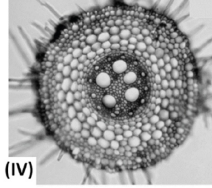
P \ Q	<input type="checkbox"/> A <input checked="" type="checkbox"/> B	<input checked="" type="checkbox"/> A <input type="checkbox"/> B
<input checked="" type="checkbox"/> 1 <input type="checkbox"/> 2	 (I)	 (II)
<input type="checkbox"/> 1 <input checked="" type="checkbox"/> 2	 (III)	 (IV)

Aerenchyma formation is a root anatomical response induced by waterlogging to increase air space inside the roots. Root sections (I) and (II) show air spaces in the aerenchyma area, which are indicated by the arrows. The aerenchyma is not seen in root sections (III) and (IV). Therefore, the conditions in the top and bottom rows are ‘waterlogged’ and ‘well-drained’, respectively.

According to the graph, genotype A developed more aerenchyma than genotype B. Comparing the root section (I) with the root section (II), both of which were from waterlogging condition, the root section (II) shows more aerenchyma. Thus, the genotypes of (I) and (II) are ‘B’ and ‘A’, respectively.

Marking Scheme

Point	1.3	0.4	0
Criteria	4 correct answers for all genotypes and conditions	2 correct answers for either both genotypes or both conditions	Incorrect or incomplete answers for genotypes and conditions

References

Pang, J., Zhou, M., Mendham, N., & Shabala, S. (2004). Growth and physiological responses of six barley genotypes to waterlogging and subsequent recovery. *Australian Journal of Agricultural Research*, 55(8), 895-906.

Urry, L. A., Cain, M. L., Wasserman, S. A., Minorsky, P. V., Orr, R. B., & Campbell, N. A. (2021). *Campbell biology* (12th ed.). Pearson. pp. 768-769.

B5. (1.8pt)

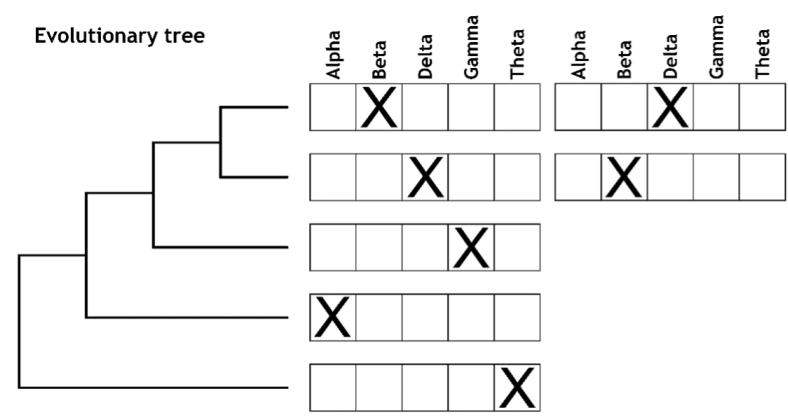

Question		Answer				
		Alpha	Beta	Delta	Gamma	Theta
1	Which pair of LAB strains is least closely related? (0.4pt)		X			X
2	Which pair of LAB strains most likely shares a recent common ancestor? (0.4pt)		X	X		

Explanation

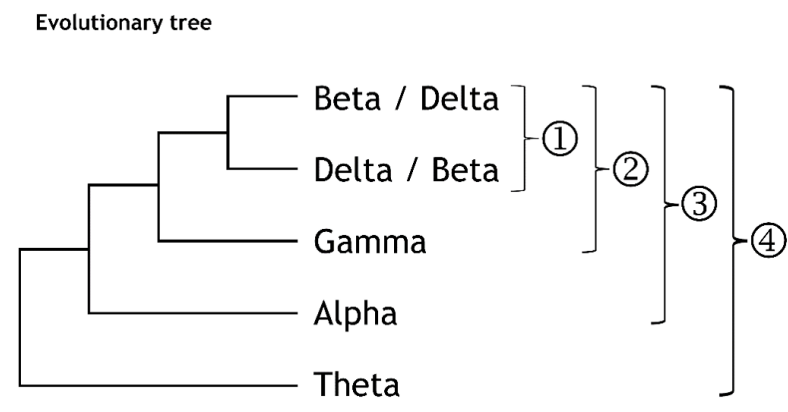

- Beta and Delta are grouped together by having the smallest percentage of base difference of 9.
- Gamma-Beta and Gamma-Delta are grouped together by having percentage of base differences of 11 and 12, respectively.
- Considering all pairwise distances, it is shown that Alpha is more closely related to Beta-Delta-Gamma group.

- Theta is less closely related to other LAB strains because it has higher percentage of base differences with all strains.

Table B5B

Question		Answer
1	Which pair of LAB strains is least closely related? (0.4pt)	Beta-Theta pair is least closely related because it has the highest percentage of base difference (25).
2	Which pair of LAB strains most likely shares a recent common ancestor? (0.4pt)	Beta-Delta pair most likely shares a recent common ancestor because it has the lowest percentage of base difference (9).

Marking Scheme for the evolutionary tree: 0.2pt for each correct answer

Remark: The positions of Beta and Delta can be switched.

Marking scheme for Table B5B: 0.4pt for each correct pair

Reference

Urry, L. A., Cain, M. L., Wasserman, S. A., Minorsky, P. V., Orr, R. B., & Campbell, N. A. (2021). *Campbell biology* (12th ed.). Pearson. p. 910.

B6. (1.8pt)

Statement	Is it likely?		Potential cause or effect?		Explanation
	Yes	No	Cause	Effect	
1. Wildlife poaching in nearby forests has reduced the local elephant population.		X			Elephants are important transport links of nutrients and their decline could decrease nutrient availability; however, because Som's plantation is securely fenced off - the elephants would be kept out - so their decline would be irrelevant to Som's farm.
2. Eutrophication may occur in Jam's pond.		X			Runoff of excess nutrients could result in eutrophication; however, Jam's pond is upstream of Som's plantation and would not be affected by runoff from Som's plantation.
3. Declining local seabird populations has led to decreased availability of P in the soil.	X		X		Local seabird populations are a key sea-to-land transport link of P. Birds get P from hunting in the sea and transporting it onto land by excretion. Seabird decline can cause a decrease in P availability on Som's plantation.
4. Prolonged El Niño events have led to many years of increased drought.	X		X		El Niño leads to drought, which decreases soil quality and its ability to hold nutrients. These then lead to decreased P availability.
5. Fishkill in nearby rivers may result from toxic chemicals.		X			Fishkill would be a result of toxic chemicals, but toxic chemicals are irrelevant here.
6. Fish in Nook's pond may die due to a lack of oxygen.	X			X	Nook's pond may receive runoff of excess nutrients from Som's plantation, which could lead to eutrophication. This would result in increasing biological oxygen demand (BOD), lowering the amount of dissolved oxygen (DO) in the water, and hence resulting in fish death.



Points: 30

Time: 3 Hours

Marking Scheme

0.2pt for each correct answer

Reference

Urry, L. A., Cain, M. L., Wasserman, S. A., Minorsky, P. V., Orr, R. B., & Campbell, N. A. (2021). *Campbell biology* (12th ed.). Pearson. pp. 1164-1189.
